

## Battery Information and Sizing

All standalone and battery-backup PV systems require battery storage. Photovoltaic modules charge the batteries during daylight hours and the batteries supply the power when it is needed, often at night and during cloudy weather. Utility grid-tie systems supply power directly to the utility grid; no battery storage is needed.

The two most common types of rechargeable batteries in use today are lead-acid and alkaline. Lead acid batteries have plates

made of lead, mixed with other materials, submerged in a sulfuric acid solution. We do not list nickel-cadmium batteries in this catalog because of their high cost and environmental problems related to disposal. Nickel metal hydride and lithium ion batteries look promising for the future, but at this time their price is much too high for the size needed for all but the smallest of remote lighting systems.

## Battery Size

The size of the battery bank required depends on the storage capacity required, the maximum discharge rate, the maximum charge rate, and the minimum temperature at which the batteries will be used. When designing a power system, all these factors are looked at and the one requiring the largest capacity will dictate battery size. Temperature has a significant effect on lead-acid batteries. At 40°F they will have 75% of rated capacity, and at 0°F their capacity drops to 50%. The storage capacity of a battery, the amount of electrical energy it can hold, is usually expressed in amp-hours. If one amp is used for 100 hours, then 100 amp-hours have been used. A battery in a PV power system should have sufficient amp-hour capacity to supply needed power during the longest expected period of cloudy weather. A lead-acid battery should be sized at least 20% larger than this amount. If there is a source of backup power, such as a standby generator with a battery charger, the battery bank does not have to be sized for worst-case weather conditions.

## Lead-Acid Batteries

Lead-acid batteries are the most common in PV systems because their initial cost is lower and because they are readily available nearly everywhere in the world. There are many different sizes and designs of lead-acid batteries, but the most important designation is whether they are deep cycle batteries or shallow-cycle batteries. Shallow-cycle batteries, like the starting batteries in automobiles, are designed to supply a large amount of current for a short time and to stand mild overcharge without losing electrolyte. However, they cannot tolerate being deeply discharged. If they are repeatedly discharged more than 20% their life will be very short. These batteries are not a good choice for a PV system. Deep cycle batteries are designed to be repeatedly discharged by as much as 80% of their capacity so they are a good choice for PV systems. Even though they are designed to withstand deep cycling, these batteries will have a longer life if the cycles are shallower. All lead-acid batteries fail prematurely when they are not recharged completely after each cycle. Letting a lead-acid battery stay in a discharged condition for days at a time will cause a permanent loss of capacity. Sealed deep cycle lead-acid batteries (gel cells and absorbed glass mat) are maintenance-free. They never need watering or an equalization charge. Sealed batteries require very accurate regulation to prevent over-charge and over-discharge. Either of these conditions will drastically shorten their lives. We recommend sealed batteries for remote, unattended power systems.

## Caring for Lead-Acid Batteries

Always use extreme caution when handling batteries and electrolyte. Wear gloves, goggles and old clothes. "Battery acid" will burn skin and eyes and destroy cotton and wool clothing.

The quickest way to ruin lead-acid batteries is to discharge them deeply and let them stand "dead" for an extended time. The positive plates change from lead oxide when charged to lead sulfate when discharged. If they remain in the lead sulfate state for a few days, part of the plate does not return to lead oxide when the battery is recharged. The parts of the plates that become "sulfated" no longer store energy.

Batteries that are deeply discharged and then charged partially on a regular basis can fail in less than one year. Check your batteries on a regular basis to be sure they are getting charged. Use a hydrometer to check the specific gravity of your lead-acid batteries. If batteries are cycled very deeply and then recharged slowly, the specific gravity reading will be lower because of incomplete mixing of electrolyte. Check the electrolyte level in wet-cell batteries at least four times a year and top-off each cell with distilled water. Do not add water to discharged batteries. Electrolyte is absorbed when batteries are discharged. If you add water at this time and then recharge the battery, electrolyte will overflow and make a mess. Keep the tops of your batteries clean and check that cables are tight. Do not tighten or remove cables while charging or discharging. Any spark around batteries can cause a hydrogen explosion inside, and ruin one of the cells, and you. It is a good idea to do an equalizing charge when some cells show a variation of 0.05 specific gravity from each other. This is a long steady overcharge, bringing the battery to a gassing or bubbling state. Do not equalize sealed or gel-type batteries.

With proper care, lead-acid batteries will have a long service life and work very well in almost any power system. With poor treatment lead-acid battery life will be very short.

We strongly recommend the use of an amp-hour meter with all battery systems. See pages 121-122.

Battery warranties do not cover damage due to poor maintenance or loss of capacity from sulfation.

## Battery Wiring Diagrams

The diagrams below show typical 12-, 24- and 48-volt battery wiring configurations. Batteries can deliver extremely high current. Always install fuse protection on any positive wiring connected to batteries.

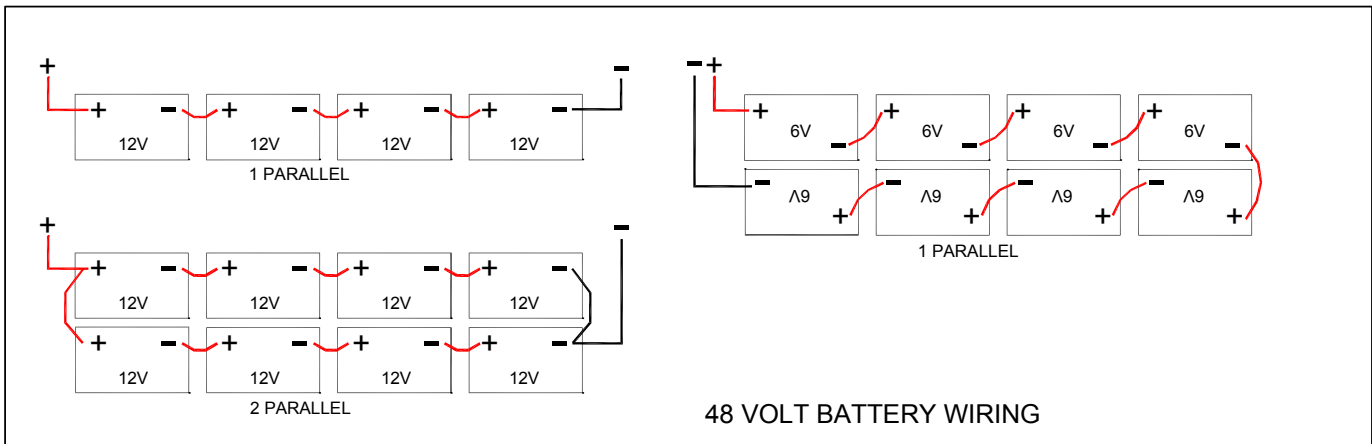
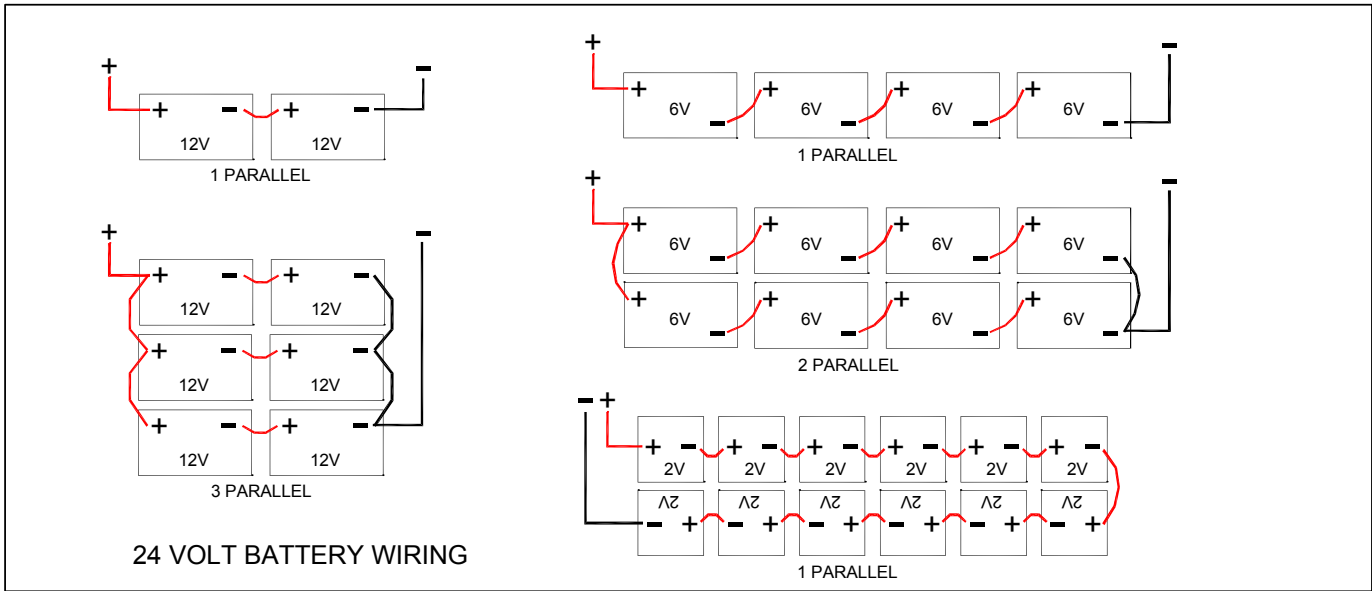
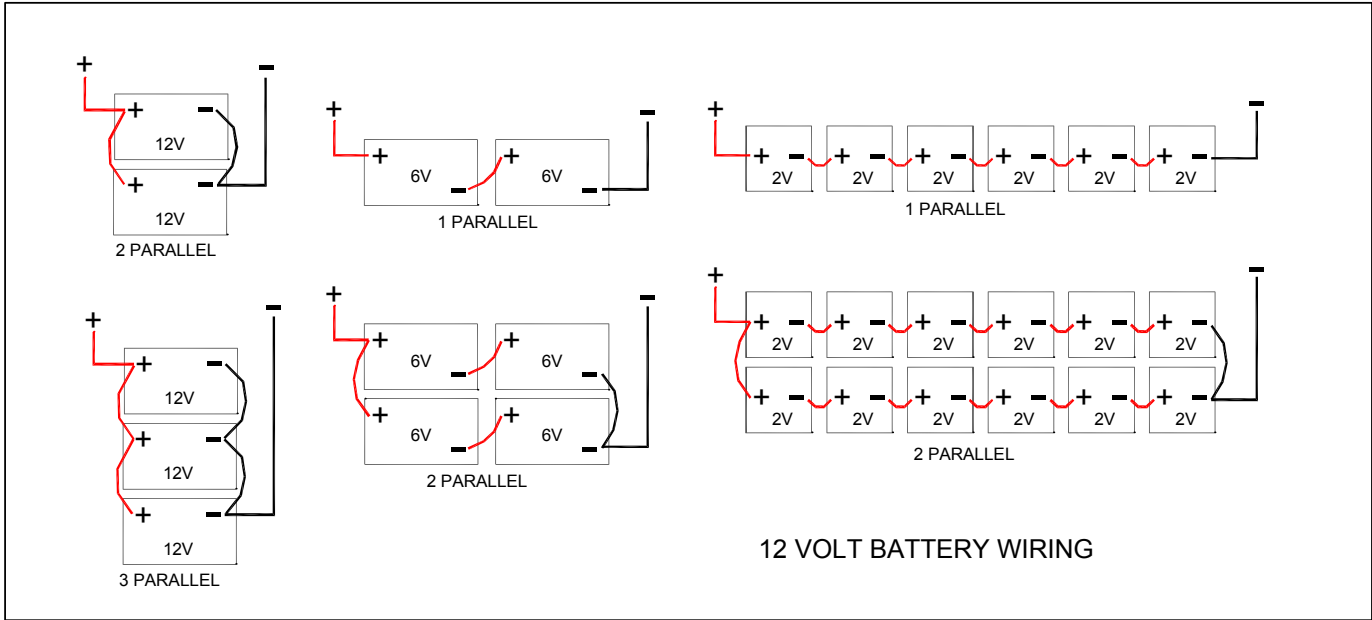

## Battery State-of-Charge

Battery state-of-charge (SOC) can be measured by an amp-hour meter, voltage or by specific gravity. Some care and knowledge is required to interpret state-of-charge from voltage or specific gravity readings. We recommend amp-hour meters for all systems with batteries.

### Amp-Hour Meters

An amp-hour meter is like having a “gas gauge” for batteries. It gives users all the information they need to keep their batteries charged. At a glance the user can see system voltage, current, and battery condition. (See the meter section for more information on amp-hour meters.)

## Measuring Battery State-of-Charge

Battery voltage will vary for the same state-of-charge depending on whether the battery is being charged or discharged, and what the current flow is in relation to the size of the battery. The table below will give you an idea of state-of-charge for various battery conditions in flooded cell lead-acid batteries. Voltage varies with temperature. While charging, a lower temperature will increase battery voltage. Full-charge voltage on a 12-volt battery is 0.9 volts higher at 32°F than at 70°F. While discharging, a higher temperature will increase battery voltage. There is little temperature effect while a battery is standing.

(Thanks to Ralph Heisy, Bogart Engineering, for this information.)

Battery condition @ 77°F	Nominal battery voltage		
	12V	24V	48V
Battery during equalization charge	Over 15	Over 30	Over 60
Battery near full charge while charging	14.4 to 15.0	28.8 to 30.0	57.6 to 60.0
Battery near full discharge while charging	12.3 to 13.2	24.6 to 26.4	49.2 to 52.8
Battery fully charged with light load	12.4 to 12.7	24.8 to 25.4	49.6 to 50.8
Battery fully charged with heavy load	11.5 to 12.5	23.0 to 25.0	46.0 to 50
No charge or discharge for 6 hours - 100% charged	12.7	25.4	50.8
No charge or discharge for 6 hours - 80% charged	12.5	25	50
No charge or discharge for 6 hours - 60% charged	12.2	24.4	48.8
No charge or discharge for 6 hours - 40% charged	11.9	23.8	47.6
No charge or discharge for 6 hours - 20% charged	11.6	23.2	46.4
No charge or discharge for 6 hours - fully discharged	11.4	22.8	45.6
Battery near full discharge while discharging	10.2 to 11.2	20.4 to 22.4	40.8 to 44.8

## Hydrometers

A hydrometer is very accurate at measuring battery state-of-charge if you measure the electrolyte near the plates. Unfortunately, you can only measure the electrolyte at the top of the battery. When a battery is being charged or discharged, a chemical reaction takes place at the border between the lead plates and the electrolyte. During charging, the electrolyte changes from water to sulfuric acid. The acid becomes stronger and the specific gravity rises as the battery charges. Near the end of the charging cycle gas bubbles rising through the acid stirs the fluid to mix it. It takes several hours for the electrolyte to mix so that you get an accurate reading at the top of the battery. Always try to take readings after a period of no charge or discharge.

### Hydrometer Readings

The table below shows battery state-of-charge at various specific gravities. These readings are correct at 75 degrees F.

State of charge	Specific gravity
100% charged	1.265
75% charged	1.239
50% charged	1.2
25% charged	1.17
Fully discharged	1.11

## Battery Sizing Worksheet

Use this worksheet to determine what size battery is required for your system. Battery size is measured in amp-hours. This is a measure of battery capacity. Battery voltage is determined by the number of “cells” in series. All lead-acid battery cells have a nominal output of 2 volts. Actual cell voltage varies from about 1.7 volts at full discharge to 2.4 volts at full charge. 12-volt lead-acid batteries are made of 6 separate cells in one case. 6-volt batteries are made of 3 cells in one case. Putting battery cells in parallel increases amp-hour capacity, but does not change voltage.

Battery temperature	Multiplier
80°F/26.7°C	1
70°F/21.2°C	1.04
60°F/15.6°C	1.11
50°F/10.0°C	1.19
40°F/4.4°C	1.3
30°F/-1.1°C	1.4
20°F/-6.7°C	1.59

**Step 1** Total average amp-hours per day required (line 10 from the Off-Grid Load Worksheet on page 13): \_\_\_\_\_

**Step 2** Maximum number of continuous cloudy days expected in your area : \_\_\_\_\_

**Step 3** Multiply line 1 by line 2: \_\_\_\_\_

**Step 4** Divide line 3 by 0.8 to maintain a 20% reserve after deep discharge period.  
(Dividing line 3 by a more conservative 0.5 will maintain a 50% reserve and increase battery life): \_\_\_\_\_

If no special conditions below apply, skip to line 9:

### Special Condition #1: Heavy Electrical Load

**Step 5** Maximum amperage that will be drawn by the loads for 10 minutes or more : \_\_\_\_\_

**Step 6** Multiply line 5 by line 5.0: \_\_\_\_\_

### Special Condition #2: High-Charge Current

**Step 7** Maximum output amperage of PV array or other battery charger : \_\_\_\_\_

**Step 8** Multiply line 7 by 5.0: \_\_\_\_\_

**Step 9** Amp-hours from line 4, 6 or 8, whichever is largest : \_\_\_\_\_

**Step 10** If you are using a lead acid battery, select the multiplier from the battery temperature table above which corresponds to the battery’s wintertime average ambient temperature: \_\_\_\_\_

**Step 11** Multiply line 9 by line 10. This is your optimum battery size in amp-hours: \_\_\_\_\_

**Step 12** Amp-hours of battery chosen. (Industrial Cell, T105=220, L16=350, etc.): \_\_\_\_\_

**Step 13** Divide line 11 by line 12. This is the total number of batteries in parallel required: \_\_\_\_\_

**Step 14** Round off to the next highest whole number. This is the number of parallel strings required: \_\_\_\_\_

**Step 15** To determine the number of batteries required in series, divide the system voltage (12, 24, or 48) by the voltage of the chosen battery (2V, 6V or 12V): \_\_\_\_\_

**Step 16** Multiply line 14 by line 15.  
This is the total number of system batteries needed for the chosen battery: \_\_\_\_\_

# East Penn

## MK Battery

### Sealed PV/Solar Batteries

MK sealed batteries are designed for maintenance-free operation for the life of the battery. Sealed construction eliminates periodic watering, corrosive acid fumes and spills. Tank formed plates ensure voltage matching between cells. Most models are rated non-spillable by ICAO, IATA and DOT, meaning easy transportation by air and no special containers are needed. Exceptions are the three asterisked AGM models below, which cannot be shipped by air freight or UPS and must be shipped by truck freight on pallets. 1-year warranty.

### MK Sealed Gel Batteries

The gelled electrolyte won't stratify, so no equalization charging is required. Less than 2% per month standby loss means low discharge during transport and storage. Gel batteries are best for cycling operations and where very cold temperatures are expected. They can operate at temperatures from -76 to 140 F.

### MK Sealed AGM Batteries

These are completely sealed, absorbed glass mat, valve-regulated batteries with efficient recombination. UL Recognized components to UL MH17218. AGM batteries are recommended for battery backup standby power systems where batteries are in float service with occasional deep discharges. They can operate at temperatures from -40 to 140 F. Delivered from one of 20 MK warehouses across the US. NOTE: The 3 asterisked models below can NOT be shipped by air or UPS, only by truck freight.



Battery type	Model number	Volts	Terminals	Capacity (Ah)		Dimensions (in) L x W x H	Weight lbs	Item code	Price
				20-hr rate	100-hr rate				
Sealed gel solar batteries	SU1-SLD-G	12	T874	31.2	36.1	7.8 x 5.2 x 7.3	24	040-03015	\$119
	S222NF-SLD-G	12	T881	50	57	9.38 x 5.5 x 9.25	38	040-03018	\$202
	S24-SLD-G	12	T881	73.6	84	10.9 x 6.8 x 9.9	53.6	040-03022	\$270
	S27-SLD-G	12	T876	86.4	99	12.75 x 6.75 x 9.75	63.2	040-03024	\$294
	S31-SLD-G	12	T876	97.6	108	12.94 x 6.75 x 9.75	71.7	040-03027	\$329
	S4D-SLD-G	12	T975	183	210	20.8 x 8.5 x 10	130	040-03030	\$640
	S8D-SLD-G	12	T975	225	265	20.8 x 11 x 10	161	040-03033	\$779
	SV6GC-SLD-G	6	T881	180	198	10.3 x 7.2 x 10.9	69	040-03036	\$356
Sealed AGM solar batteries	8AU1	12	T874	32.5	37	7.8 x 5.2 x 7.3	24	040-03117	\$100
	8A22NF	12	T881	55	63	9.38 x 5.5 x 9.25	38	040-03120	\$184
	8A24	12	T881	79	91	10.9 x 6.8 x 9.9	53.6	040-03123	\$231
	8A27	12	T876	92	106	12.75 x 6.75 x 9.75	63.2	040-03126	\$275
	8A31 *	12	T876	105	116.2	12.94 x 6.75 x 9.75	71.7	040-03129	\$315
	8A4D *	12	T975	200	216	20.8 x 8.5 x 10	130	040-03132	\$588
	8A8D *	12	T975	245	257	20.8 x 11 x 10	161	040-03135	\$693
	8AGC2	6	T881	200	220	10.3 x 7.2 x 10.9	69	040-03137	\$315

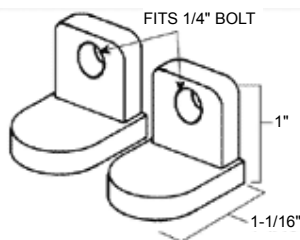

**T874**

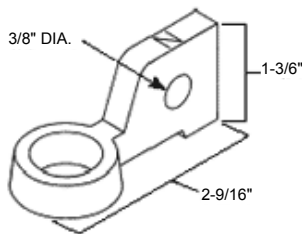

**T876**

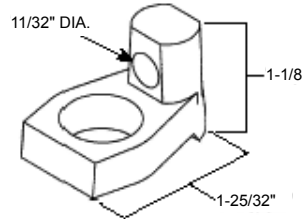

**T881**

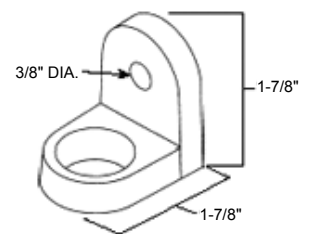

**T975**

## NEW! MK 8L-16 6-Volt Deep Cycle Battery

This version of East Penn's MK L-16 battery is the best commercial deep cycle battery value we offer. They have flag terminals and a heavy duty plastic case. MK L-16 batteries are made in USA. They seem to be able to maintain the best price on this type of battery because they own their own lead smelter which allows them to have better control of lead prices. Capacity is 370 amp-hours at a 20-hour rate and 420 amp-hours at a 100-hour rate.

Model	Volts	Dimensions (in)	Weight lbs	Item code	Price
8L-16	6	11.75 x 7 x 17.3	113	040-01957	\$410



## Trojan Commercial Deep Cycle Lead Acid Batteries

These batteries have been used in off-grid power systems in remote cabins for the past 25 years with great success. Because of their low initial cost, they are the most affordable true, deep cycle batteries. The T105 golf cart battery is designed to be used in small electric vehicles where they are cycled heavily and last about 2 years. In a remote home system where they are cycled down 20% every day they can last 3 to 6 years. The L-16 battery is designed for electric floor scrubbing machines. They are a heavy-duty cousin of the golf cart battery with much thicker lead plates and nearly twice the capacity. The L-16 is available in a standard and a high-capacity version. The standard version holds more electrolyte and has a slightly longer life.

The SCS-series 12-volt marine batteries are Trojan's top of the line 12-volt deep cycle batteries. They are designed for marine and RV use and work well in small cabin systems where 110 to 130 amp-hours is enough storage.



Model	Volts	Capacity (Ah) 20-hour rate	Dimensions (in)	Weight lbs	Item code	Price
T-105	6	225	10.375 x 7.125 x 11.25	62	040-01939	\$223
L-16PO	6	390	11.625 x 7 x 16.75	113	040-01963	\$545
L-16HC	6	420	11.625 x 7 x 16.75	121	040-01964	\$605
SCS150	12	110	11.25 X 6.75 X 9.75	50	040-01921	\$263
SCS225	12	130	13.25 X 6.75 X 9.75	66	040-01927	\$320

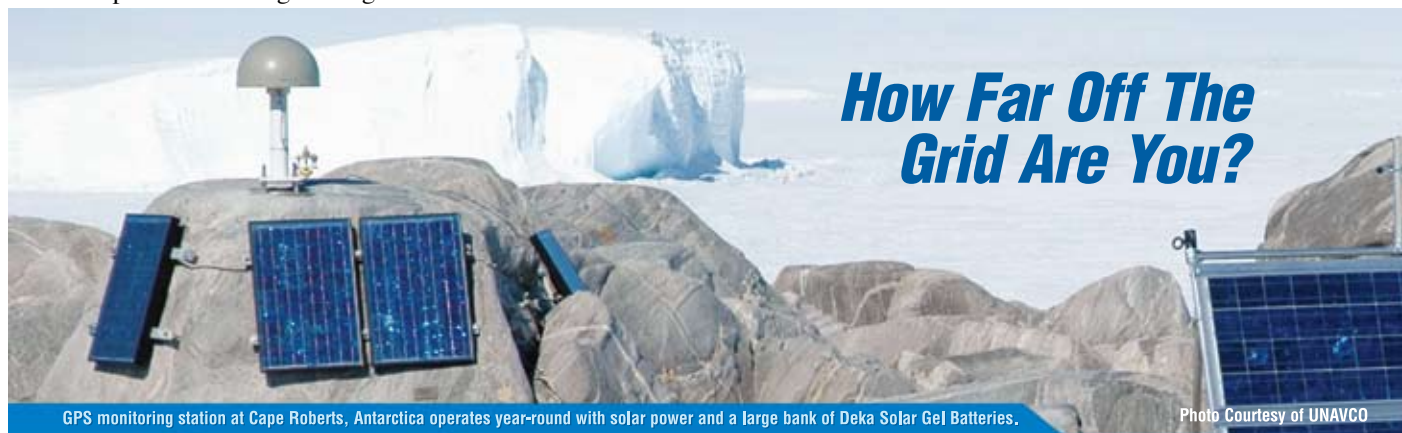

### How Far Off The Grid Are You?

GPS monitoring station at Cape Roberts, Antarctica operates year-round with solar power and a large bank of Deka Solar Gel Batteries.

Photo Courtesy of UNAVCO

### No matter where you are, depend on Deka Solar.

Antarctica is the coldest continent on the planet. Only the toughest plants and animals are able to survive the cold. And the same goes for your batteries. So when a government funded agency needed to deploy a photovoltaic system for monitoring land mass movement in this harsh environment, they chose Deka Solar Batteries.

Whatever the demands of your renewable energy application, Deka Solar Gel/AGM or flooded batteries are the proven choice.



DOMESTIC INQUIRIES:  
800-372-9253 • [www.mkbattery.com](http://www.mkbattery.com)

**EAST PENN**  
manufacturing co., Inc.

INTERNATIONAL INQUIRIES:  
610-682-3263 • [www.dekabatteries.com](http://www.dekabatteries.com)



PROVEN PRODUCTS IN DEMANDING PHOTOVOLTAIC APPLICATIONS • U.L. RECOGNIZED COMPONENTS • COMPETITIVE WARRANTY • MADE IN THE U.S.A.

## Rolls/Surrette Battery

### Deep Cycle Industrial Flooded Batteries

These are the new generation, dual container, deep cycle Rolls batteries from Surrette. (S-460 and S-530 are not dual container). They are high-capacity batteries with heavy duty plate grid to resist positive plate breakdown. The plates are double insulated with glass mat and a polyethylene envelope, eliminating the possibility of separator misalignment, cracked separators, treeing or shorting at the bottoms or sides. Rolls batteries are rated at 3200 cycles at 50% depth of discharge except for S-460 and S-530 which are rated at 1000 cycles. Each 2-volt cell is built into its own lightweight container made of durable polypropylene with the cover heat bonded to the container, thus acid leakage is eliminated. The cells are then assembled into a tough, lightweight polyethylene outer container with a removable lid. Even if the outer container were to break, the battery would still be operable without acid spills. The individual cells are bolted together (CS and KS series) allowing the battery to be disassembled and the cells can be independently removed.



This facilitates easy on-site installation, disassembly, assembly, or replacements of individual cells without special skills or tools. All Surrette CS & KS deep cycle solar batteries come with a 10-year warranty, 3-year full warranty, and 7-year prorated.

Batteries shipped to commercial addresses qualify for free shipping to different regions of the country as follows:

- **East of the Mississippi:**

S-460s and S-530s – 18 batteries or more  
All other batteries – greater than 2000 pounds

- **West of the Mississippi, east of the Rockies:**

S-460s and S-530s – 36 batteries or more  
All other batteries – greater than 4000 pounds

- **West of the Rockies:**

S-460s and S-530s – 54 batteries or more  
All other batteries – greater than 6000 pounds

Surrette model	Battery voltage	Capacity (Ah)		Rated cycles (50% DOD)	Warranty (years)	Dimensions (inches)			Weight wet / dry	Item code	Price
		20-hr rate	100-hr rate			L	W	H			
2-KS-33PS	2	1766	2491	3300	10	15.44	8.31	24.81	208/145	040-02220	\$913
2-YS-31PS	2	2430	3435	3300	10	15.50	9.00	31.63	285/200	040-02221	\$1432
4-CS-17P	4	546	770	3200	10	14.38	8.25	18.25	128 / 98	040-02223	\$525
4-KS-21P	4	1104	1557	3200	10	15.75	9.38	24.75	267 / 186	040-02226	\$790
4-KS-25P	4	1350	1900	3200	10	15.75	10.63	24.75	315 / 220	040-02229	\$1236
S-460	6	350	460	1000	7	12.28	7.12	16.75	117 / 90	040-02106	\$333
S-530	6	400	530	1000	7	12.28	7.12	16.75	125 / 105	040-02109	\$366
6-CS-17PS	6	546	770	3200	10	22	8.25	18.25	221 / 178	040-02232	\$824
6-CS-21PS	6	683	963	3200	10	22	9.75	18.25	271 / 217	040-02235	\$957
6-CS-25PS	6	820	1156	3200	10	22	11.25	18.25	318 / 254	040-02238	\$1130
8-CS-17PS	8	546	770	3200	10	28.25	8.25	18.25	294 / 238	040-02247	\$1050
8-CS-25PS	8	820	1156	3200	10	28.25	11.25	18.25	424 / 342	040-02250	\$1535
12-CS-11PS	12	357	503	3200	10	22	11.25	18.25	272 / 220	040-02259	\$1001

# HuP Solar-One

## 2100 Cycle Industrial Batteries

The Solar-One battery with HuP Technology is optimized for renewable energy systems. It has a slightly enlarged epoxy-coated steel case that allows cell removal and easier installation without a forklift or crane. Solar-One batteries are designed with 0.310" thick positive plates and a patented technology that allows them to be warranted for 2100 cycles to 80% DOD. The 10 year-warranty, 7-year free replacement and 3 years prorated is the best in the RE

industry. Each Solar-One is made up of six 2-volt cells and comes with stainless steel hardware, lead-plated copper buss bars, a cell lifting strap and an operator/installation manual. Order two for 24-volt systems or four for 48-volt systems. Many sizes are in stock and available for immediate shipment. Other sizes are made to order; please allow up to 8 weeks for delivery. Free shipping to a commercial location in the lower 48 states.



Cell type	Capacity @ 20-hr rate	Weight lbs	Dimensions L" x w" x 25" h	Item code	Price
SO-6-85-17	845 A-H	742	40" x 7.75"	040-05269-A	\$1,959
SO-6-85-19	950 A-H	808	40" x 8.25"	040-05272	\$2,099
SO-6-85-21	1055 A-H	880	40" x 8.75"	040-05275	\$2,169
SO-6-85-23	1160 A-H	959	40" x 9.0"	040-05278	\$2,315
SO-6-85-25	1270 A-H	1036	40" x 10.25"	040-05281	\$2,425
SO-6-85-27	1375 A-H	1102	40" x 11.25"	040-05284	\$2,500
SO-6-85-31	1585 A-H	1252	40" x 12.75"	040-05290	\$2,899
SO-6-85-33	1690 A-H	1336	40" x 13.5"	040-05293	\$2,999

## IBE

### POWR-Plus Solar Batteries

POWR-Plus batteries are designed to give more energy and maximum battery life. All batteries are custom built when an order is received. All batteries have high capacity industrial type deep cycle cells with flag type terminals on the positive and negative posts. Heat-sealed cell covers eliminate the major source of electrolyte leakage, reducing corrosion build-up. Tough steel cases are powder coated for acid resistance and have lifting handles.

Cycle life of these batteries is 5,000 cycles at 20% depth of discharge or 1500 cycles at 80% depth of discharge.

We list 12-volt packs that can be combined for 24- or 48-volt systems. IBE can also supply 2-volt cells with the same high quality cells, for use when the batteries must be moved by hand.

IBE batteries have an 8-year warranty. The first 5 years are full replacement. The last 3 years are prorated.

Cell type	Capacity @ 20-hr rate	Capacity @ 100-hr rate	Weight lbs	Dimensions L" x W" x 24" H	Item code	Price
<b>12V POWR-Plus Solar Batteries</b>						
Pp-6-85-9	418 A-h	510 A-h	490	21.5 X 6.62	040-07209	\$1,229
Pp-6-85-11	523 A-h	638 A-h	630	26.5 X 6.62	040-07211	\$1,382
Pp-6-85-13	627 A-h	765 A-h	670	30.75 X 6.62	040-07213	\$1,493
Pp-6-85-15	732 A-h	893 A-h	710	18 X 13	040-07215	\$1,698
Pp-6-85-17	836 A-h	1020 A-h	790	20.25 X 13	040-07217	\$1,848
Pp-6-85-19	941 A-h	1148 A-h	905	22.38 X 13	040-07219	\$2,034
Pp-6-85-21	1046 A-h	1275 A-h	1006	24.75 X 13	040-07221	\$2,171
Pp-6-85-23	1160 A-h	1403 A-h	1080	27 X 13	040-07223	\$2,304
Pp-6-85-25	1255 A-h	1530 A-h	1160	29.25 X 13	040-07225	\$2,516
Pp-6-85-27	1359 A-h	1658 A-h	1240	31.5 X 13	040-07227	\$2,663
Pp-6-85-29	1464 A-h	1785 A-h	1325	33.75 X 13	040-07229	\$2,913
Pp-6-85-31	1568 A-h	1913 A-h	1389	36 X 13	040-07231	\$3,177
Pp-6-85-33	1673 A-h	2040 A-h	1480	38.25 X 13	040-07233	\$3,497
<b>2V POWR-Plus Solar Batteries</b>						
PP-1-85-17	836 A-H	1020 A-H	138	6.62 x 6.88	040-07155	\$399
PP-1-85-19	941 A-H	1148 A-H	146	6.62 x 7.62	040-07157	\$429
PP-1-85-21	1046 A-H	1275 A-H	168	6.62 x 8.38	040-07159	\$451
PP-1-85-23	1160 A-H	1403 A-H	180	6.62 x 9.12	040-07161	\$473
PP-1-85-25	1255 A-H	1530 A-H	194	6.62 x 9.88	040-07163	\$510
PP-1-85-27	1359 A-H	1658 A-H	208	6.62 x 10.62	040-07165	\$533
PP-1-85-29	1464 A-H	1785 A-H	224	6.62 x 11.38	040-07167	\$575
PP-1-85-31	1568 A-H	1913 A-H	238	6.62 x 12.12	040-07169	\$619
PP-1-85-33	1673 A-H	2040 A-H	252	6.62 x 12.88	040-07171	\$672

# GNB

## Absolyte IIP Industrial Sealed Batteries

The Absolyte battery was developed by GNB, in conjunction with Sandia National Laboratories, as the first VRLA, large capacity, deep cycle battery for photovoltaic applications. This design provides for extended partial state-of-charge operation and allows for deep discharge recovery. Their wide band of temperature operation, from -40°C (-40°F) to +50°C (122°F), retains more capacity in cold temperatures than traditional flooded batteries. Life expectancy in float conditions is 20 years @ 25°C (77°F) with proper charging. Life expectancy in cycling conditions is 1200 cycles to 80% DOD with proper charging. Sealed cells with absorbed glass mat (AGM) separators eliminate the need for periodic water additions as found in flooded cells. Periodic visual inspections, voltage readings, and connection retorquing are all that is required.

Protective steel tray housings offer maximum installation flexibility and the Absolute IIP is qualified to stack horizontally up to eight high for use in 1997 UBC/2001 CBC Seismic Zone IV (at or below grade). This provides for high capacity in a small footprint and frees up floor space for other equipment; and because they are sealed, they do not require a separate battery room.

They are IEC 896, BS 6290, UL Recognized, ISO 9001:2000, designed to meet Telcordia SR4228 and GR-63-CORE (NEBS).



## Applications

Absolyte IIP batteries are ideal for photovoltaic and alternative energy applications including:

- Village electrification
- Telecommunications
- Residential power
- Railroad signal
- Navigational aids



GNB part #	Volts	Capacity (Ah)		Length (in.)	Width (in.)	Height (depth) (in.)	Weight lbs	Item code	Price	
		20-hr rate	100-hr rate							
<b>6-Cell 12-Volt Batteries</b>										
6-50a05	12	120	145	17.19	8.53	16.22	157	040-04409	\$2,052	
6-50a07	12	182	220	21.69	8.53	16.22	209	040-04412	\$2,430	
6-50a09	12	240	290	26.19	8.53	16.22	252	040-04415	\$2,873	
6-50a13	12	360	440	35.19	8.53	16.22	356	040-04421	\$3,672	
6-90a07	12	300	365	21.69	8.53	23.56	316	040-04430	\$3,062	
6-90a09	12	400	490	26.19	8.53	23.56	396	040-04433	\$3,576	
6-90a11	12	500	610	30.69	8.53	23.56	477	040-04436	\$4,217	
6-90a13	12	600	730	35.19	8.53	23.56	557	040-04439	\$4,925	
6-90a15	12	700	855	39.69	8.59	23.56	637	040-04442	\$5,400	
<b>3-Cell 6-Volt Batteries</b>										
3-100a19	6	1,020	1,200	26.75	8.59	26.38	470	040-04322	\$3,507	
3-100a21	6	1,140	1,330	29.00	8.59	26.38	515	040-04325	\$3,804	
3-100a27	6	1,460	1,730	35.75	8.59	26.38	653	040-04334	\$4,722	
3-100a29	6	1,580	1,860	38.00	8.59	26.38	704	040-04337	\$5,073	
3-100a31	6	1,700	1,995	40.25	8.59	26.38	750	040-04340	\$5,432	
3-100a33	6	1,820	2,130	42.50	8.59	26.38	795	040-04343	\$5,778	
<b>2-Volt Cells</b>										
1-100a39	2	2,040	2,400	19.93	8.53	26.38	328	040-04225	\$2,525	
1-100a45	2	2,340	2,795	22.18	8.59	26.38	374	040-04228	\$2,893	
1-100a51	2	2,700	3,190	24.50	8.59	26.38	424	040-04231	\$3,225	
1-100a57	2	3,060	3,590	26.75	8.59	26.38	470	040-04234	\$3,512	
1-100a63	2	3,420	3,990	29.00	8.59	26.38	515	040-04237	\$3,819	
1-100a69	2	3,780	4,390	31.25	8.59	26.38	561	040-04240	\$4,094	
1-100a75	2	4,080	4,790	33.50	8.59	26.38	608	040-04243	\$4,382	
1-100a81	2	4,440	5,185	35.75	8.59	26.38	653	040-04246	\$4,724	
1-100a87	2	4,800	5,585	38.00	8.59	26.38	704	040-04249	\$5,075	
1-100a93	2	5,100	5,985	40.25	8.59	26.38	750	040-04252	\$5,433	
1-100a99	2	5,460	6,385	42.50	8.59	26.38	795	040-04255	\$5,780	

# East Penn

## NEW! Deka Unigy II Sealed Industrial Batteries



The Deka Unigy II line features two module designs with a wide range of capacities to fit the requirements of renewable energy applications. These batteries are ideal for float applications with an occasional deep discharge, such as battery-backup for grid-connected systems. The front safety shield design easily clips on and off without tools for quicker assembly. The modules are coated with acid resistant epoxy powder paint and each module has mounting holes for grounding option.

These batteries are available with interlocked frames for locations with tough seismic requirement and non-interlocked frames where this is not required. They are also available with flame retardant polyethylene cases. The interlocking module frames require only front access bolts for mounting, providing quick and safe installation. Their standard one-piece base enables it to be used as anchoring template. Anchors can be drilled and installed with base in place. They are certified to UBC 97 Zone 4 Top of Building up to 8 modules high. The non-interlock modules require front and rear access bolts for mounting, providing easy and safe installation. The standard two-piece base enables anchors to be drilled and installed with base in place. The non-interlock version is certified to UBC 97 Zone 2B Top of Building up to 8 modules high.

To order, pick the prefix of the battery with the capacity required, then add the suffix to indicate the case type and whether they are interlocking modules.

Item code prefix	Deka model	Amp hours		Suffix >	Non-Interlock SpaceSaver		Interlock SpaceSaver	
		20 hour rate	100 hour rate	Module volts	Flame retardant poly case	Standard polycase	Flame retardant poly case	Standard poly case
					-NL	-NS	-IL	-IS
					Price per module			
040-06011	6AVR75-5	180	210	12	\$2,134.00	\$2,089.00	\$2,343.00	\$2,296.00
040-06012	6AVR75-7	280	310	12	\$2,382.00	\$2,259.00	\$2,618.00	\$2,482.00
040-06013	6AVR75-9	380	420	12	\$2,631.00	\$2,510.00	\$2,888.00	\$2,756.00
040-06014	6AVR75-11	460	520	12	\$2,851.00	\$2,735.00	\$3,133.00	\$3,005.00
040-06015	6AVR75-13	540	630	12	\$3,109.00	\$2,986.00	\$3,418.00	\$3,280.00
040-06016	6AVR75-15	640	730	12	\$3,431.00	\$3,269.00	\$3,771.00	\$3,592.00
040-06017	3AVR75-17	720	840	6	\$2,337.00	\$2,252.00	\$2,565.00	\$2,473.00
040-06018	3AVR75-19	820	940	6	\$2,501.00	\$2,409.00	\$2,749.00	\$2,644.00
040-06019	3AVR75-21	920	1050	6	\$2,662.00	\$2,546.00	\$2,923.00	\$2,799.00
040-06022	3AVR75-23	1000	1150	6	\$2,780.00	\$2,672.00	\$3,055.00	\$2,937.00
040-06023	3AVR75-25	1100	1250	6	\$2,906.00	\$2,790.00	\$3,194.00	\$3,065.00
040-06024	3AVR75-27	1200	1360	6	\$3,063.00	\$2,926.00	\$3,366.00	\$3,215.00
040-06025	3AVR75-29	1280	1460	6	\$3,388.00	\$3,231.00	\$3,723.00	\$3,550.00
040-06026	3AVR75-31	1380	1570	6	\$3,523.00	\$3,358.00	\$3,868.00	\$3,689.00
040-06027	3AVR75-33	1460	1670	6	\$3,633.00	\$3,468.00	\$3,988.00	\$3,810.00
040-06028	6AVR95-15	790.6	941.2	12	\$3,840.00	\$3,634.00	\$4,221.00	\$3,989.00
040-06029	3AVR95-17	903.5	1075.7	6	\$2,581.00	\$2,470.00	\$2,836.00	\$2,715.00
040-06030	3AVR95-19	1016.4	1210.1	6	\$2,767.00	\$2,643.00	\$3,040.00	\$2,903.00
040-06031	3AVR95-21	1129.4	1344.6	6	\$2,942.00	\$2,805.00	\$3,231.00	\$3,083.00
040-06032	3AVR95-23	1242.3	1479	6	\$3,083.00	\$2,948.00	\$3,388.00	\$3,236.00
040-06033	3AVR95-25	1355.3	1613.5	6	\$3,232.00	\$3,087.00	\$3,551.00	\$3,394.00
040-06034	3AVR95-27	1468.2	1747.9	6	\$3,391.00	\$3,232.00	\$3,726.00	\$3,551.00
040-06035	3AVR95-29	1581.1	1882.4	6	\$3,726.00	\$3,553.00	\$4,094.00	\$3,903.00
040-06036	3AVR95-31	1694.1	2016.9	6	\$3,879.00	\$3,697.00	\$4,263.00	\$4,060.00
040-06037	3AVR95-33	1807	2151.3	6	\$4,012.00	\$3,825.00	\$4,409.00	\$4,204.00
040-06038	2AVR125-33	2367	2930	4	N/A	N/A	\$3,763.62	N/A

# Direct Power & Water

## Pole-Mount Aluminum Battery Boxes

Side-of-pole mount aluminum NEMA 3R hinged door boxes from Direct Power & Water are available for several battery sizes and battery/equipment configurations. They are made to order from 0.125" 5052- H32 aluminum with white powder coating, and can be built to meet specific application requirements. The doors have padlock hasps and stainless steel continuous hinges. Each box has a removable control mounting plate, screened vents and two 7/8" wire entrance holes.



Battery size	Batteries spaces	Dimensions (in) D x W x H	Item code	Price
Group 27, 30	1	9 X 16 x 20	048-04179	\$545
Group 27, 30	2	16 X 16 x 20	048-04188	\$660
Group 27, 30	4	16 X 16 x 20	048-04200	\$840
Group 27, 30	6	16 X 25 x 34	048-04201	\$1,020
Golf cart	2	14 X 18 x 22	048-04197	\$545
Golf cart	4	14 X 18 x 36	048-04203	\$680
4d	1	12 X 24 x 22	048-04282	\$630
4d	2	12 X 24 x 36	048-04291	\$790
8d	1	15 X 24 x 22	048-04285	\$760
8d	2	15 X 24 x 36	048-04294	\$865



## MidNite Solar

### Battery Enclosures

These grey powder-coated steel battery enclosures with locking doors are ETL Listed for the US and Canada for indoor use. They are for use with sealed AGM or gel batteries. MNBE-A ships by UPS, unassembled. MNBE-B ships by UPS unassembled in 2 boxes. MNBE-C ships by truck freight, unassembled .



MidNite model	Battery size	Batteries spaces	Dimensions (in) D x W x H	Shipping dimensions	Weight (lbs)	Item code	Price
MNBE-A	27 or 31	6	14.5 X 29 x 27.25	30" X 32" x 7.5"	71	048-05501	\$425
	8d	2					
MNBE-B	27 or 31	8	15.25 X 33.6 X 34.5	18" X 8" x 36" & 18" X 9" x 37"	102	048-05503	\$605
MNBE-C	27 or 31	12	16 X 36.5 X 55	Ships by truck on a 42" x 42" x 60" pallet	190	048-05505	\$849
	8d	3					

# Direct Power & Water

## Chest-Style Battery Enclosures

Pad mount, chest style enclosures are manufactured with 0.125" 5052-h32 aluminum. All die marks and welds are sanded smooth and the boxes are finished with a reflective bright white polyester powder coat to minimize internal heat gain. All enclosures are provided with integrated louvers located to promote convective air flow through the enclosure to reduce internal temperatures and remove gasses. Filters are located over the louvers to keep out dust and insects. The filters are removable for cleaning or replacement. All standard enclosures are built to meet NEMA 3R specifications.

Other sizes are available. For sizes not listed below, contact us for price.



Battery size	Batteries spaces	Layout	Dimensions (inches)	Weight lbs	Non-insulated		Insulated	
					Item code	Price	Item code	Price
27/30	2	2x1	16x16x16	26	048-04030	\$768	048-04033	\$1,030
	4	2x2	18x30x16	39	048-04031	\$973	048-04034	\$1,283
	4	1x4	16x34x16	37	048-04032	\$995	048-04035	\$1,314
	6	2x3	25x30x16	50	048-04140	\$1,158	048-04143	\$1,518
	8	2x4	30x33x16	60	048-04036	\$1,320	048-04043	\$1,711
	10	2x5	41x30x16	70	048-04037	\$1,469	048-04044	\$1,903
8d	2	2x1	24x26x16	44	048-04057	\$1,047	048-04065	\$1,368
	4	2x2	26x46x16	68	048-04116	\$1,433	048-04119	\$1,835
	4	1x4	24x50x16	65	048-04066	\$1,459	048-04067	\$1,871
	6	2x3	38x46x16	90	048-04128	\$1,781	048-04131	\$2,255
	8	2x4	46x50x16	111	048-04068	\$2,102	048-04069	\$2,629
	10	2x5	62x46x16	131	048-04164	\$2,400	048-04167	\$2,993
	12	2x6	46x74x16	150	048-04070	\$2,701	048-04077	\$3,431
	12	4x3	50x68x16	150	048-04071	\$2,691	048-04078	\$3,415
Golf cart	2	2x1	13x18x17	25	048-04074	\$750	048-04079	\$1,009
	4	2x2	18x25x17	37	048-04075	\$935	048-04080	\$1,236
	4	1x4	14x35x17	36	048-04076	\$980	048-04081	\$1,298
	6	2x3	25x27x17	47	048-04134	\$1,112	048-04137	\$1,462
	8	2x4	25x32x17	56	048-04152	\$1,256	048-04155	\$1,637
	10	2x5	43x25x17	65	048-04082	\$1,400	048-04089	\$1,825
	12	2x6	25x51x17	74	048-04083	\$1,547	048-04090	\$2,088
	12	4x3	34x35x17	74	048-04084	\$1,529	048-04091	\$2,056
L-16, s460, s-530	2	2x1	19x22x28	43	048-04088	\$868	048-04095	\$1,157
	4	2x2	22x32x28	61	048-04122	\$1,113	048-04125	\$1,452
	4	1x4	19x39x28	63	048-04096	\$1,155	048-04097	\$1,508
	6	2x3	31x32x28	76	048-04146	\$1,333	048-04149	\$1,726
	8	2x4	32x39x28	89	048-04158	\$1,518	048-04161	\$1,945
	10	2x5	32x48x28	102	048-04098	\$1,698	048-04099	\$2,173
	12	2x6	32x56x28	115	048-04170	\$1,882	048-04173	\$2,476
	12	4x3	39x46x28	114	048-04171	\$1,860	048-04172	\$2,446
	14	2x7	32x65x28	128	048-04174	\$2,077	048-04175	\$2,694
	16	2x8	32x73x28	141	048-04176	\$2,257	048-04177	\$2,929
	16	4x4	39x59x28	137	048-0418	\$2,194	048-04181	\$2,845

## Heavy Duty Plastic Battery Box



This battery box designed to hold eight L-16 batteries is made from high density polyethylene (HDPE) sheet.

The box has an insulated base with removable middle section that minimizes lifting, easing battery installation. The plastic is easy to drill with hole saw to attach conduit fitting for inverter cables. A hydrogen vent tube in the top should be extended to exterior of building. A drain in the bottom section makes it possible to wash batteries.



Description	Dimensions (in) H x W x D	Weight lbs	Item code	Price
HDPE battery box	18 X 30 x 26	60	048-04017	\$549

## Plywood Battery Storage Containers

These durable wooden storage units are constructed with 5/8" plywood for the bottom to provide a solid support platform. The sides, back and front are 3/4" plywood. The lid is 5/8" plywood with an overhang on the both the front and sides and is fastened using galvanized hinges to provide durability in all weather conditions. Handles are added to the lid to make it easy to open. Each box is vented on both sides and the front to provide a constant air flow. A drain plug is included in the floor for easy washing of your battery bank. Every box is finished with quality exterior paint available in black, brown or white. It can also be shipped unfinished so you can match to your home's exterior.

Top and front are removable to allow easy battery installation. Battery boxes are shipped unassembled. Assembly is easy and can be done in just a few hours with 2 people. Step by step instructions, all hardware, screws, and finishing supplies are included in every box.



Model	Battery size	Number of batteries	Dimensions (in) W x D x H	Item code	Price
A8	T105, SCS150, SCS225	8	40 x 33 x 22	048-03905	\$839
B8	L16PO, L16HC; S460, S530	8	40 x 31 x 27	048-03911	\$839
D8	Type 24, 27, 31	8	37 x 33 x 20	048-03915	\$839
A16	T105, SCS150, SCS225	16	80 x 33 x 22	048-03919	\$1,299
B16	L16PO, L16HC; S460, S530	16	80 x 31 x 27	048-03923	\$1,299



## Water Miser Battery Caps



Water Misers are molded plastic "flip-top" vent caps designed to reduce and ease maintenance on flooded lead-acid batteries. There is no need to remove the caps when charging, filling or equalizing the batteries. When charging, the plastic pellets capture up to 90% of the moisture and acid droplets. This reduces acid fumes, corrosion, and keeps the battery tops much cleaner and dryer. Excess water is dropped back into the battery cell. Water loss is reduced, which extends time between watering. These caps fit all batteries with standard caps.

Description	Item code	Price
Water Miser battery cap	040-09913	\$8.50

## IBE

### Generator-Powered Chargers



All IBE GPU models are designed with simple and time-proven controlled-reactance transformer and saturable reactor circuits, which requires the least amount of AC power, little or no maintenance and provides a true, constantly tapering charge. The IBE charger is regulated by the "ON CHARGE" battery voltage to control the output DC current. The charger is protected against overloads, short circuits, line voltage surges and reversed battery connections.

Design features include full magnetic control that automatically allows for full taper charge from high rate to maximum safe finish rate. The charging rate is easily re-adjusted to accommodate aging batteries or batteries with faulty cells.

10-year limited warranty.

IBE model	Volts	AC kW required	Max DC current		Weight lbs	Item code	Price
			Start	Continuous			
6GPU60	12	0.84	60	42	48	045-04105	\$650
6GPU70	12	1.1	70	49	68	045-04107	\$780
6GPU90	12	1.4	90	63	76	045-04109	\$870
6GPU100	12	1.6	100	70	83	045-04111	\$940
6GPU125	12	1.9	125	88	102	045-04117	\$1,070
6GPU150	12	2.3	150	105	115	045-04119	\$1,180
6GPU170	12	2.6	170	119	120	045-04121	\$1,280
6GPU200	12	3.1	200	140	130	045-04123	\$1,445
6GPU240	12	3.7	240	168	150	045-04125	\$1,790
6GPU270	12	4.2	270	189	180	045-04127	\$2,040
12GPU60	24	1.9	60	42	75	045-04145	\$810
12GPU70	24	2.2	70	49	82	045-04147	\$930
12GPU90	24	2.9	90	63	103	045-04149	\$1,075
12GPU100	24	3.1	100	70	114	045-04151	\$1,155
12GPU115	24	3.6	115	81	132	045-04153	\$1,275
12GPU125	24	4.1	125	88	138	045-04155	\$1,370
12GPU150	24	4.7	150	105	154	045-04157	\$1,470
12GPU170	24	5	170	119	160	045-04159	\$1,565
12GPU200	24	6	200	140	178	045-04161	\$1,755
12GPU240	24	7	240	168	204	045-04163	\$1,990
12GPU270	24	8	270	189	220	045-04165	\$2,290
24GPU60	48	3.8	60	42	112	045-04207	\$1,290
24GPU70	48	4.4	70	49	143	045-04209	\$1,440
24GPU90	48	5.8	90	63	154	045-04211	\$1,580
24GPU100	48	6	100	70	165	045-04213	\$1,720
24GPU115	48	6.8	115	81	182	045-04215	\$1,880
24GPU125	48	7.7	125	88	188	045-04217	\$1,990
24GPU150	48	9.3	150	105	196	045-04219	\$2,120
24GPU170	48	10.5	170	119	204	045-04221	\$2,310
24GPU200	48	12.5	200	140	227	045-04223	\$2,570

## Xantrex

### Truecharge 40+ Charger

Truecharge 40+ is a high reliability 40-amp electronic battery charger for deep cycle batteries. Switch settings give correct charge for wet, gel cell, or absorbed glass mat (AGM) batteries. Selectable 2- or 3-stage charging where 3-stage includes float charge. Manual equalize charge button. Manual or automatic temperature compensation. Optional temperature sensing probe to correct charge voltage for actual battery temperature. This charger has full 40-amp output even with low-cost generators, which is important when using the charger with a 1000- to 3000-watt generator. Dimensions: 2.75" x 6.7" x 15.1". 1-year warranty.

Description	Item code	Price
Truecharge 40+ charger	045-02885	\$450
Temperature sensor	045-02889	\$30
Remote control panel	045-02888	\$40



## IOTA

### DLS Converter/Chargers

The DLS series converter/power supply output is so clean and ripple-free, it can be used with or without a battery. The DLS series converter/charger quickly and efficiently charges batteries from the full rated output of the DLS. The DLS then maintains the batteries, only putting into the battery what is required by load or self discharge, cutting back to milliamps as the battery requires. Low and transient AC line voltage can be a major cause of converter/power supply failure. The DLS series converter/power supply is protected against low line voltage, as well as spikes coming from the AC power source or from improperly adjusted generators. When used as a power supply, the DLS model will only supply what is required by the load.



IOTA model	Battery volts	Charge amps	Dimensions (inches)	Weight lbs	Item code	Price
DLS-15	12	15	7 x 6.5 x 3.5	4	045-02112	\$132
DLS-30	12	30	7 x 6.5 x 3.5	5.5	045-02115	\$171
DLS-45	12	45	7 x 6.5 x 3.5	5.5	045-02118	\$183
DLS-55	12	55	7 x 6.5 x 3.5	5.5	045-02121	\$215
DLS-75	12	75	10 x 6.5 x 3.5	7.8	045-02124	\$440
DLS-90	12	90	10 x 6.5 x 3.5	7.8	045-02127	\$497
DLS-27/15	24	15	7 x 6.5 x 3.5	5.5	045-02130	\$281
DLS27/25	24	25	7 x 6.5 x 3.5	5.5	045-02133	\$335
DLS-27/40	24	40	10 x 6.5 x 3.5	7.8	045-02136	\$545
DLS-54/15	48	15	10 x 6.5 x 3.5	7.8	045-02148	\$545
IQ-4	12	Smart Controller for 12V Chargers			045-02103	\$30

When not in use it is essentially off, reducing electricity usage. External fuses can be quickly and easily replaced.

Chargers have 120 VAC input. 75-amp and larger chargers have 120V 20-amp plugs. 2-year warranty

#### IOTA IQ-4 Smart Controller

The IQ-4 makes the DLS charger into 3-stage charge with bulk, absorption and float charging. If the battery remains in float stage for 7 days, it delivers a bulk charge. The IQ-4 is not recommended for generator-powered battery charging if generator is only run for short periods of time.

## Samlex

### Battery Chargers

These compact, lightweight, multi-stage battery chargers are designed to charge and maintain lead-acid and gel-cell batteries, without supervision. Safely charge and condition marine, recreational vehicle, industrial and automotive batteries. They can charge multiple banks of batteries.

Chargers have 120VAC input. 1-year warranty.



Samlex model	Battery volts	Bulk voltage	Float voltage	Max DC current	Amp meter	Isolated banks	Dimensions (inches)	Weight lbs	Item code	Price
SEC-1215A	12	14.4	13.8	15	Yes	3	8.4 x 8.4 x 3.25	5.0	045-03073	\$162
SEC-1230A	12	14.4	13.8	30	Yes	3	10.7 x 8.4 x 3.25	5.3	045-03076	\$266
SEC-1245A	12	14.4	13.8	45	No	2	12 x 9 x 4	11.1	045-03079	\$410
SEC-2415A	24	28.8	27.6	15	Yes	3	10.7 x 8.4 x 3.3	5.3	045-03082	\$266
SEC-2425A	24	28.8	27.6	25	No	2	12 x 9 x 4	11.1	045-03085	\$410



## QuickCote

### Anti-Corrosion Protectant

QuickCote offers a complete acid neutralizing coating, formulated especially for battery terminals and exposed electrical connections. The 8-ounce can has a brush-on applicator that will give years of use and cannot clog like aerosol coatings.

Description	Item code	Price
QuickCote	046-00195	\$20

## BD-2

### Battery Desulfator

The BD-2 battery desulfator from Solar Converters rejuvenates weak and dead batteries. It uses sharp spikes of current forced into the battery to “jar” sulfate crystals and cause mechanical and electrical resonance to grind them down, removing sulfation from battery plates. It can be used for 12-, 24- and 48-volt batteries. Voltage and pulse strength is adjustable. Two wires connect to positive and negative battery terminals. 1-year warranty.



Description	Item code	Price
BD-2 battery desulfator	045-07105	\$125

## Battery Power Solutions

### Desulfators

The BLS-12-A from Battery Power Solutions is for use on vehicles that are used frequently and have one or two batteries. Also for use with a battery bank that operates at 12 volts. Runs constantly to keep the battery in optimum condition. Can also be used for battery storage in conjunction with a float charger. Comes with eye rings for attachment to the battery clamp bolts.



BLS-12/24-B is a higher powered version of BLS-12-A. For use with a battery charger to rejuvenate unusable batteries. Works faster than BLS-12/24-A. Comes with plier type battery clips.

BLS-12/24-C is for use on heavy trucks and other vehicles and systems with multiple batteries. Runs constantly to keep batteries in optimum condition. Comes with 5/16" lugs for attachment to the battery clamp bolts.

BLS-36-A is a 36-volt version for use with battery powered vehicles. Can be mounted on the vehicle to constantly keep the batteries in optimum condition or can be used in conjunction with a battery charger. Comes with 3/8" lugs for attachment to the battery terminals.

BLS-48-A is a 48-volt version for use with battery powered vehicles and for battery banks that operate at 48 volts. Can be mounted on the vehicle to constantly keep the batteries in optimum condition or can be used in conjunction with a battery charger. Comes with 3/8" lugs for attachment to the battery terminals.

Description	Item code	Price
BLS-12-A	045-07161	\$60
BLS-12/24-B	045-07163	\$96
BLS-12/24-C	045-07165	\$96
BLS-36-A	045-07167	\$96
BLS-48-A	045-07169	\$96

## Zephyr

### Power Vent Battery Box Vent

Lead-acid batteries produce hydrogen gas when charging. But if the battery box is left open to vent gas in cold climates, the batteries get too cold and battery capacity is significantly reduced. A vent that solves this problem is especially important when battery boxes are placed in basements, garages and sheds. When heat rises in the structure, a low pressure area forms around the box, cool air flows into the box and gases vent into the structure. The Power Vent controls battery box venting, removing hydrogen gas while reducing cold air infiltration into the box. The Power Vent



contains a gravity-operated damper that normally stays closed. When connected to a voltage-controlled relay, the fan operates only when the batteries are being charged and blows gas vapors out. Designed for battery banks under 2200 Ah and charge rates under 125 amps. Fan can be operated from the auxiliary relay on a Xantrex XW inverter, from the auxiliary relay of an OutBack FX inverter (use 12 volt-fan for all OutBack inverter voltages) or by a voltage controlled switch (sold separately on page 117.) The 12/24-volt unit uses 3 watts and pushes air at 6 CFM with a 360° maximum change of direction. Dimensions: 4" diameter x 7.25" with a 2" PVC pipe socket on the inlet and outlet. The 48-volt unit uses 6 watts and pushes 8 CFM with a 360° maximum change of direction. Dimensions: 4" diameter x 10" long, with a 3" PVC pipe socket on the inlet and outlet.

Description	Item code	Price
Power vent 12V	085-08205	\$79
Power vent 24V	085-08207	\$79
Power vent 48V	085-08209	\$104

### Hydrometers

Reads actual specific gravity for an accurate measurement of battery state of charge. Float type has built-in thermometer for temperature correction. Variation of 0.20 or greater specific gravity between battery cells indicates a need for battery equalization charging or a weak cell.



Description	Item code	Price
Hydrometer float type	046-00154	\$8
Hydrometer dial type	046-00156	\$8